



VOV / WorldDMB Workshop on Digital Radio Technologies

27-29 July 2013

*The Melia Hotel & VOV HQ Building,
Hanoi, Vietnam*



Supported by



DAB+ Network Planning and Deployment

Friday 26 July 2013, Session 4

Dr. Les Sabel - WorldDMB Technical Committee

DAB+ Transmission Network Planning

The Journey

The transmission network design process is a journey!



DAB+ Transmission Network Planning

Overview

System Requirements

Spectrum and Capacity Requirements

Coverage Targets

Regulatory Considerations

Network Design

Terrain, Licence Areas and Interference

Equipment and Construction

Performance Verification

The Journey Continues

Top Tips

DAB+ Transmission Network Planning

System Requirements

DAB+ Transmission Network Planning

System Requirements

Key considerations

- Which broadcasters wish to be involved?
- How many services are expected / what are the rules regarding bit-rate/CU allocation?
- Selecting areas to provide service
 - Licence Area Plans (LAPs), cities, targeting your audience
 - Pocket or blanket coverage
- Working with your regulator
 - Making the playing field fair
 - Planning across multiple areas
 - Multiple broadcasters
 - Multiple broadcaster types – Commercial, National, Community, Narrowcast

DAB+ Transmission Network Planning

Spectrum and Capacity Requirements

DAB+ Transmission Network Planning

Spectrum and Capacity Requirements

- Spectrum
 - What is available?
 - VHF and L-Band
 - Multiple Frequency Network planning – cellular design
 - Power levels
 - Coverage vs Co-Channel Interference (CCI) and Adjacent Channel Interference (ACI) with other/adjacent cells / LAPs
 - CCI with other LAPs/cells and ACI to/from DAB+, ATV, DTV, Horizontal Polarisation (HPOL) v Vertical Polarisation (VPOL)
 - Example ACI/CCI requirements from the ACMA / Regulator
 - Beam tilt to help minimise inter-cell interference
 - E.g. Brisbane CCI issue

DAB+ Transmission Network Planning

Spectrum and Capacity Requirements

- Capacity
 - How much spectrum is available OR How much spectrum is REQUIRED?
 - E.g. Sydney uses 3 ensembles (5.136MHz) for approx 54 services
 - How many services (now and later)
 - Number of services per area?
 - MFN design
 - spectrum reuse, typical cellular design requires 3-4 times single cell capacity dependant on terrain and coverage requirements
 - Service capacity for audio and PAD
 - PAD is important – timed SLS delivery

DAB+ Transmission Network Planning

Coverage Targets

DAB+ Transmission Network Planning

Coverage Targets

Grades of service

- Several grades of service from vehicle to better than urban
- In-building penetration
 - Building types and density have significant impact
 - Ground level vs high levels, opposite side of building
 - MATV solutions in high-rise
 - Micro gap fillers
- Cars generally OK if in-building performance is satisfactory

Impact of Indonesian environment

- Tropical rain – wet foliage attenuation
- High-rise and concrete buildings – significant density?
- Across sea propagation
 - Pro - long distance coverage
 - Con – may cause interference to other transmitters, may not be suitable for SFN

DAB+ Transmission Network Planning

Commercial Radio Planning targets

Maximum allowed Field Strength = 120dBuV/m (1V/m)

potential near field
electronic equipment
interference

| | FIELD STRENGTH |
|--|------------------------------|
| | Urban Indoor & Vehicle |
| | Suburban Indoor & Vehicle |
| | Vehicle Only |

> 63 dBuV/m

57 – 63 dBuV/m

50 – 57 dBuV/m

| >=dBuV/m/OAA | Label |
|--------------|-------|
| 35 | |
| 40 | |
| 45 | |
| 50 | |
| 57 | |
| 63 | |
| 83 | |

Below 50dBuV/m is considered to provide unreliable coverage

Some areas may receive some coverage but patchy coverage is unsatisfactory

DAB+ Transmission Network Planning

Regulatory Considerations

DAB+ Transmission Network Planning

Regulatory Considerations

- Working with your regulator to create a standard
 - Need to have the same technical operating parameters for all broadcasters in the same market
 - Clear rules and understand encourages focus on the real business of delivering great **content**
 - Maximise coverage area
 - Minimise Co-Channel and Adjacent Channel Interference

The Regulator defines the operating parameters the broadcaster designs a solution which meets those requirements

DAB+ Transmission Network Planning

Regulatory Considerations

ACMA defined Protection Ratios

See www.acma.gov.au

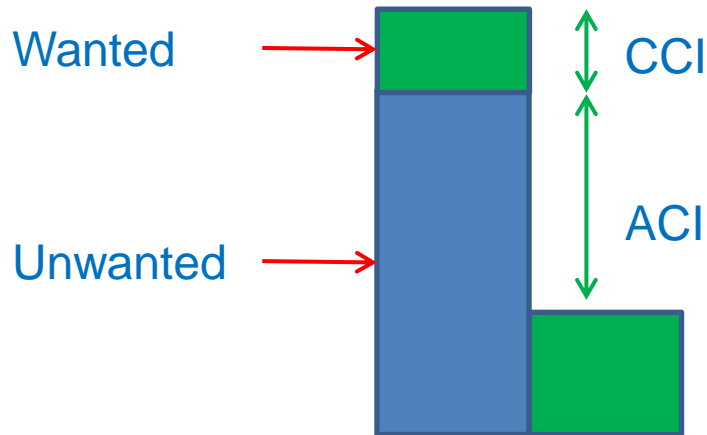

| Unwanted transmitter | | | | Wanted Service | | | | | | | | |
|----------------------|---|---|---|--|----------------------------------|--|--|-----------------------------------|---|---|----------------------------------|---|
| A | B | C | D | Digital Radio (DAB) Frequency Block(s) of potentially interfering service within the relevant TV channel | Analog TV co-channel (Channel N) | Analog TV Lower Adjacent channel (Channel N-1) | Analog TV Upper Adjacent channel (Channel N+1) | Digital TV co-channel (Channel N) | Digital TV Lower Adjacent channel (Channel N-1) | Digital TV Upper Adjacent channel (Channel N+1) | Digital Radio co-frequency block | Digital Radio Adjacent frequency block (Lower or Upper) |
| | | | | | | | | | | | | |
| A | | | | | 38 | 5 | -8 | 22 | -9 | -30 | 15 | -40 |
| | B | | | | 40 | -4 | -3 | 22 | -30 | -30 | 15 | -40 |
| | | C | | | 34 | -5 | -2 | 22 | -30 | -30 | 15 | -40 |
| | | | D | | 39 | -5 | 0 | 22 | -30 | -9 | 15 | -40 |
| A | B | | | | 42 | 5 | -3 | 25* | -9 | -30 | | |
| A | | C | | | 39 | 5 | -1 | 25* | -9 | -30 | | |
| A | | | D | | 42 | 5 | 1 | 25* | -9 | -9 | | |
| | B | C | | | 41 | -2 | 0 | 25* | -30 | -30 | | |
| | B | | D | | 43 | -2 | 2 | 25* | -30 | -9 | | |
| | | C | D | | 40 | -2 | 3 | 25* | -30 | -9 | | |
| A | B | C | | | 43 | 5 | 2 | 25 | -9 | -30 | | |
| | B | C | D | | 43 | 0 | 3 | 25 | -30 | -9 | | |
| A | | C | D | | 42 | 5 | 3 | 25 | -9 | -9 | | |
| A | B | | D | | 44 | 5 | 2 | 25 | -9 | -9 | | |
| A | B | C | D | | 44 | 5 | 4 | 25 | -9 | -9 | | |

DAB+ Transmission Network Planning

Network Design

DAB+ Transmission Network Planning

The Design Cycle

- A cooperative and collaborative process between both broadcasters and the regulator
- Site selection
- Antenna selection
 - Patterns - CCI protection to other areas
 - Down tilt
 - Efficiency – higher gain = lower power costs
 - DC grounded antennas 
- Combine DAB+ ensembles at same site/antenna
 - minimise ACI issues with VHF TV
 - Minimise in-band DAB ensemble issues
 - Collocate with VHF TV
 - Minimises Inter-Modulation issues (balanced combining)
 - Best practice

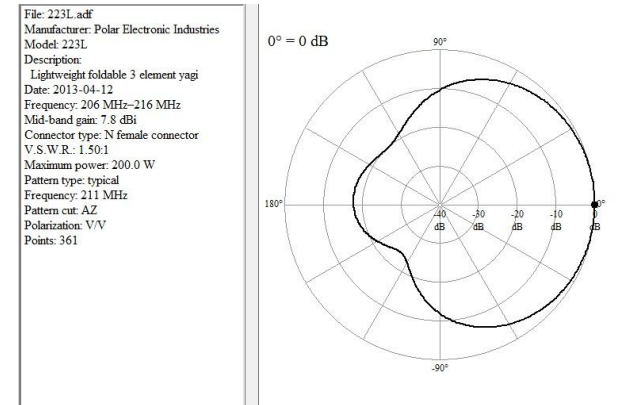

Save Money / Make Money

DAB+ Transmission Network Planning

The Design Cycle – Coverage Modelling

- Model coverage then interference
- Main high power site first, then in-fills
- Antenna pattern and down tilt (if required)
- Tuning the model
 - cartography
 - propagation model
 - clutter parameters
- Test transmission at lower power will allow more accurate design through empirical verification in the field
 - At least for initial sites
 - Is terrain / vegetation dependant

DAB+ Transmission Network Planning

The Design Cycle

- The first loop is the hardest
- A test transmission will provide the best learning experience
- Use the initial system results to help design future systems

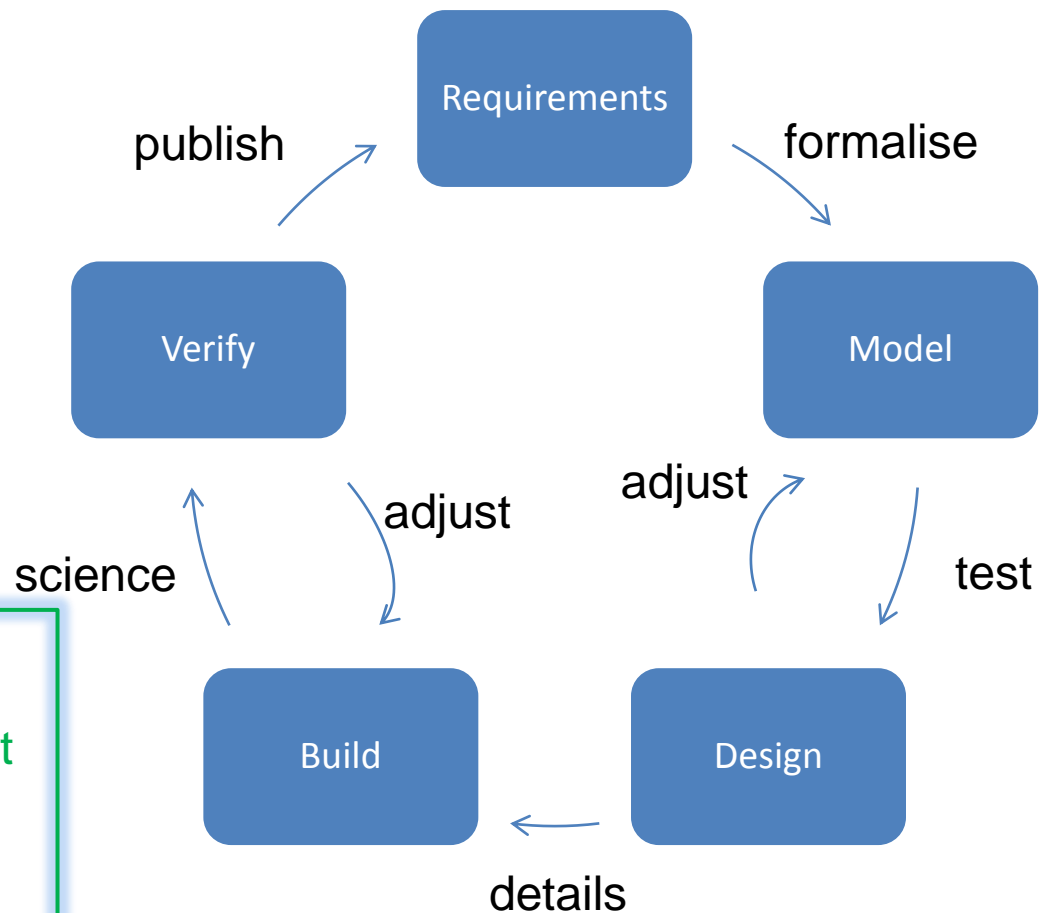

Engineering collaboration helps minimise the system design and deployment effort and maximises benefits to listeners and in turn broadcaster returns

DAB+ Transmission Network Planning

Multi-Frequency Networks and Single Frequency Networks

- Single frequency network.
- Several medium and low power transmitters

SFNs are a more efficient use of spectrum

MFN

e.g. Main Tx and 2 Gap Fillers

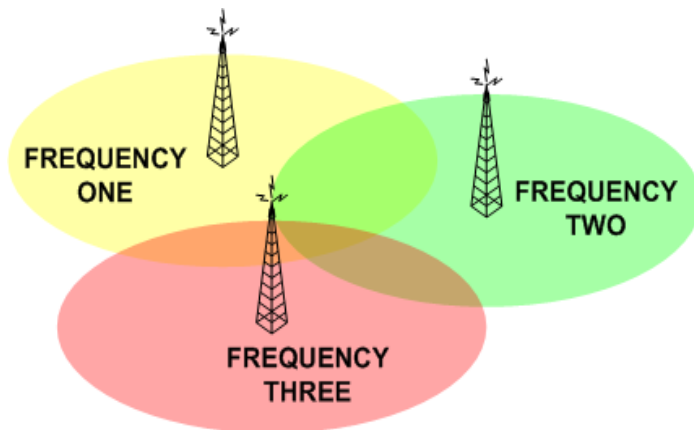

SFN

e.g. Main Tx and 2 Gap Fillers

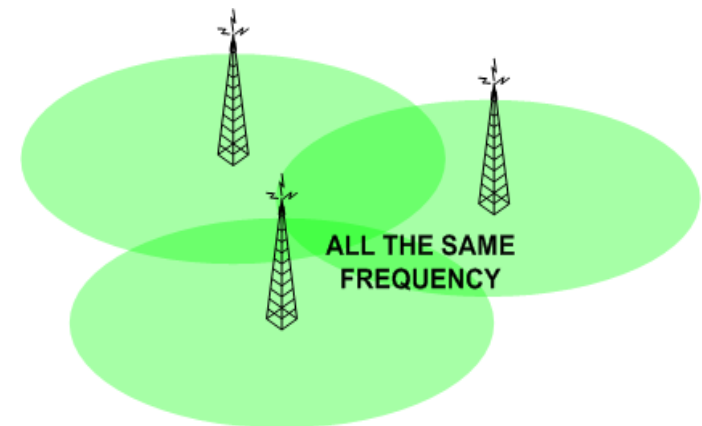

DAB+ Transmission Network Planning

RF Network Options

Covering a specific area
e.g. A Licence Area

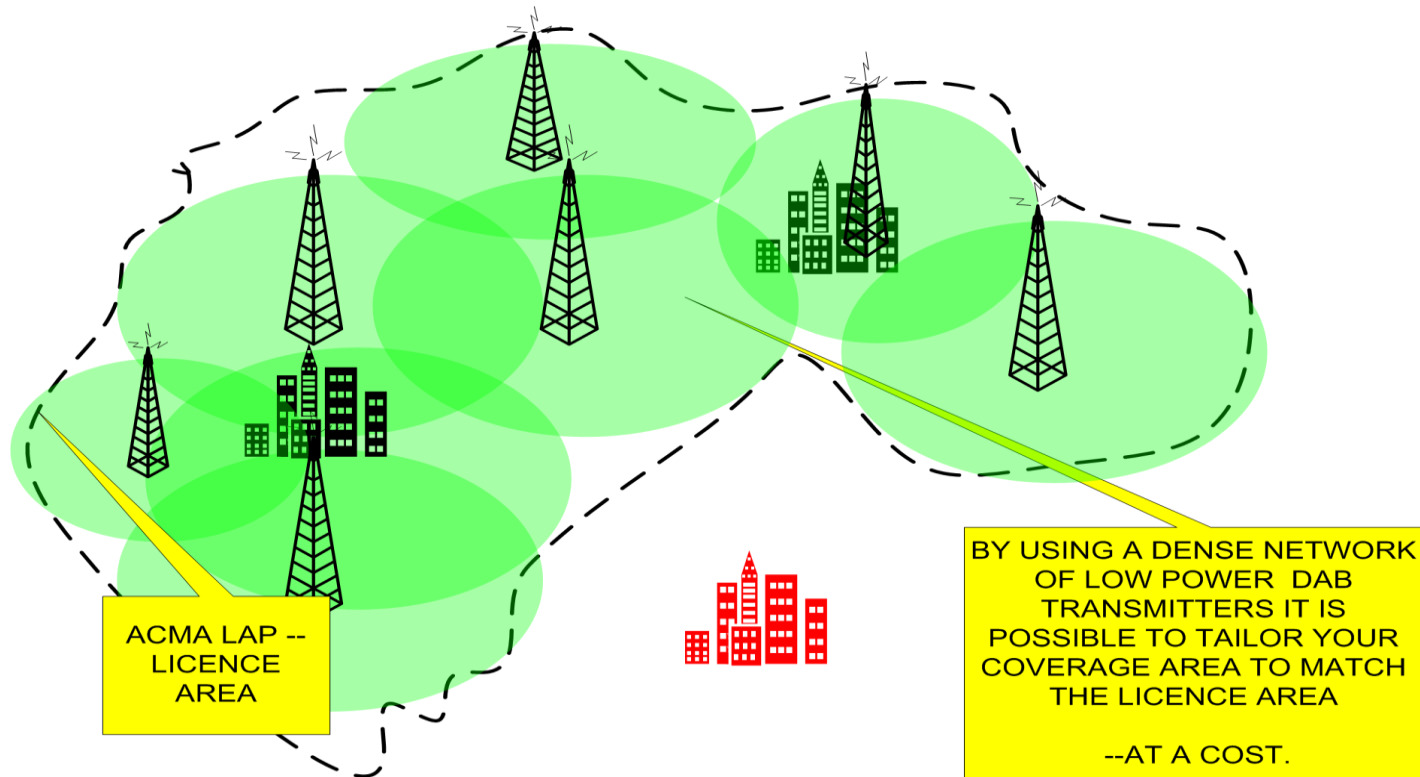

DAB+ Transmission Network Planning

Typical DAB+ SFN

- Single frequency network.
- Several medium and low power transmitters

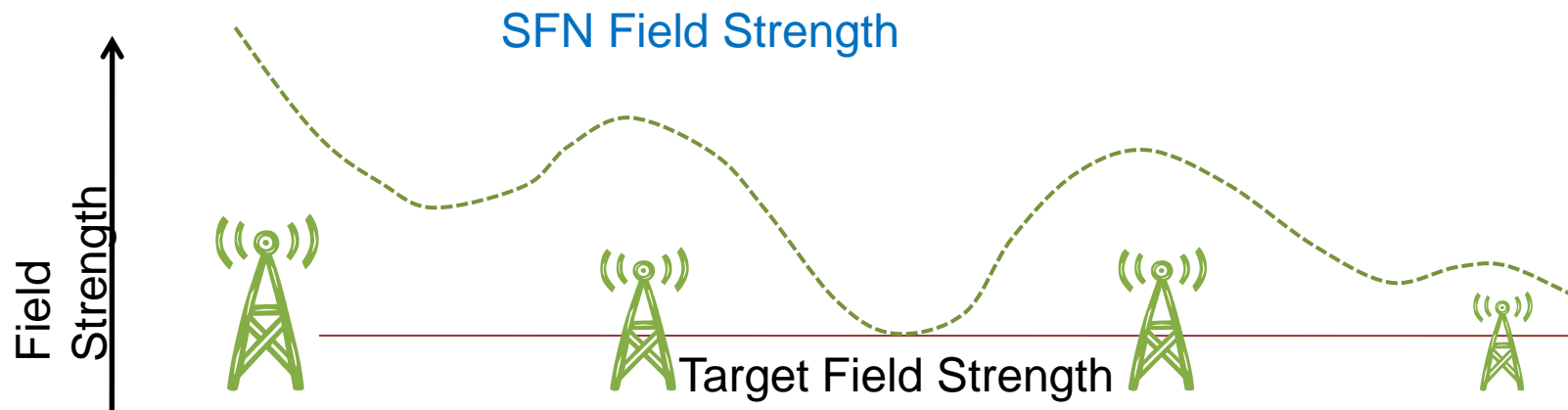

DAB+ Transmission Network Planning

Problems with TV in Same Band

- Existing TV viewers will experience interference

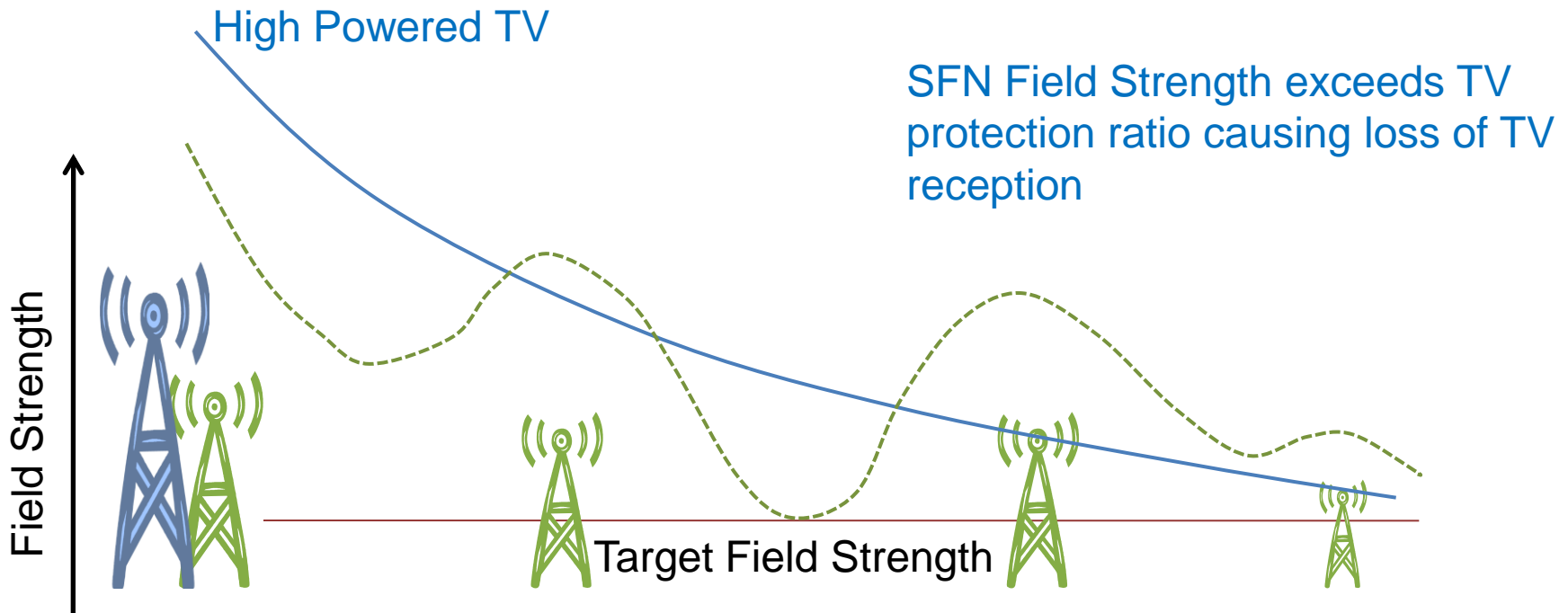

DAB+ Transmission Network Planning

Co-Sited Transmitters

- If a high power DAB+ transmitter is placed at or near the same location as TV transmitters – interference to TV viewers is minimised.
- 50 kW ERP DAB+ transmitters are typical in Australia.

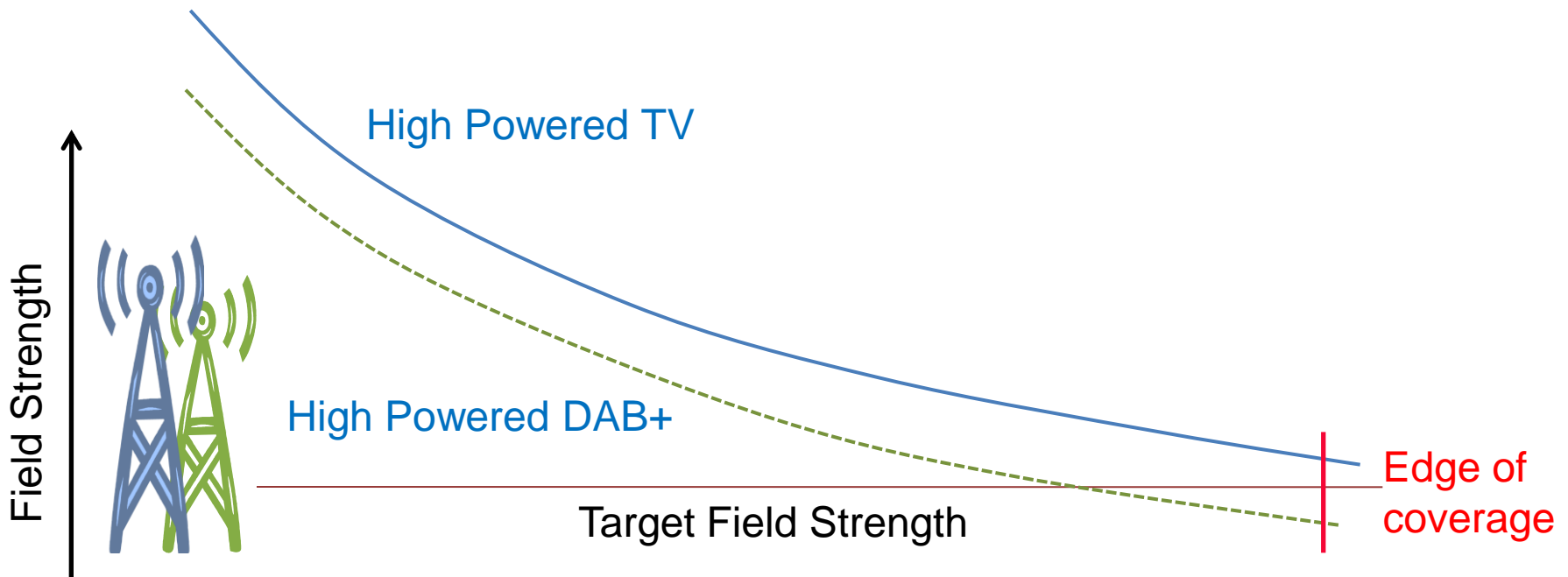

DAB+ Transmission Network Planning

Co-Sited Transmitters

- Some black spots may still occur in CBD and edge of coverage areas.
- Low power repeaters can be employed to fill black spots
 - 300-500W ERP
 - >500W ERP in regional areas

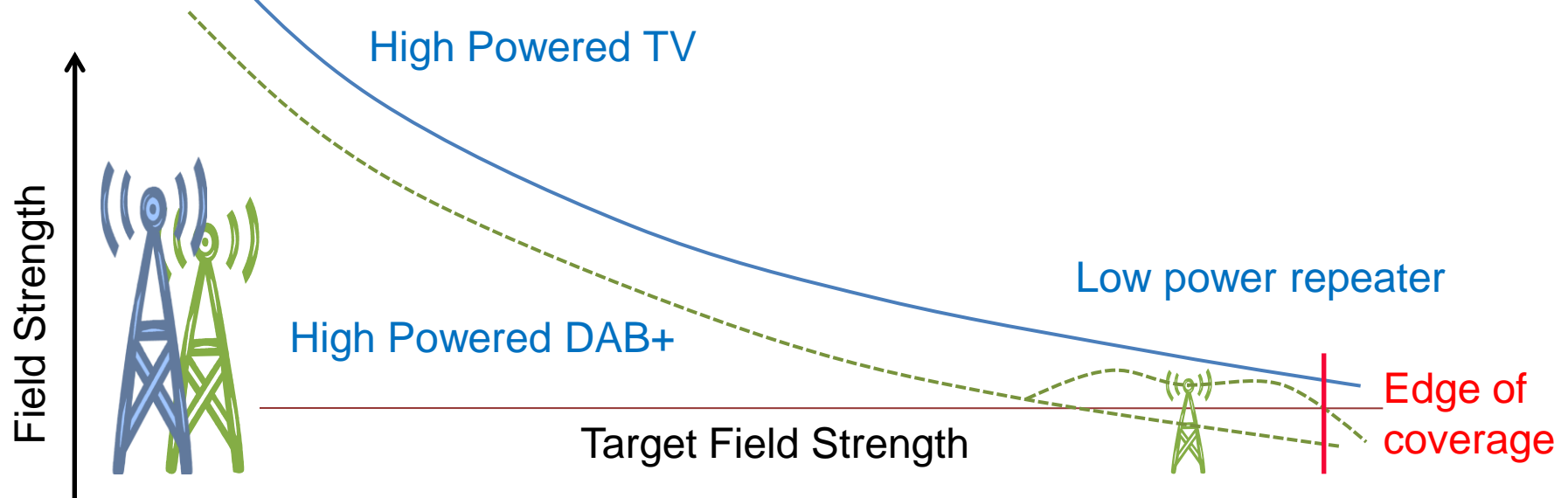

DAB+ Transmission Network Planning

Costs of Repeaters

On-Channel repeaters reduce costs by eliminating the need for Telco or microwave links

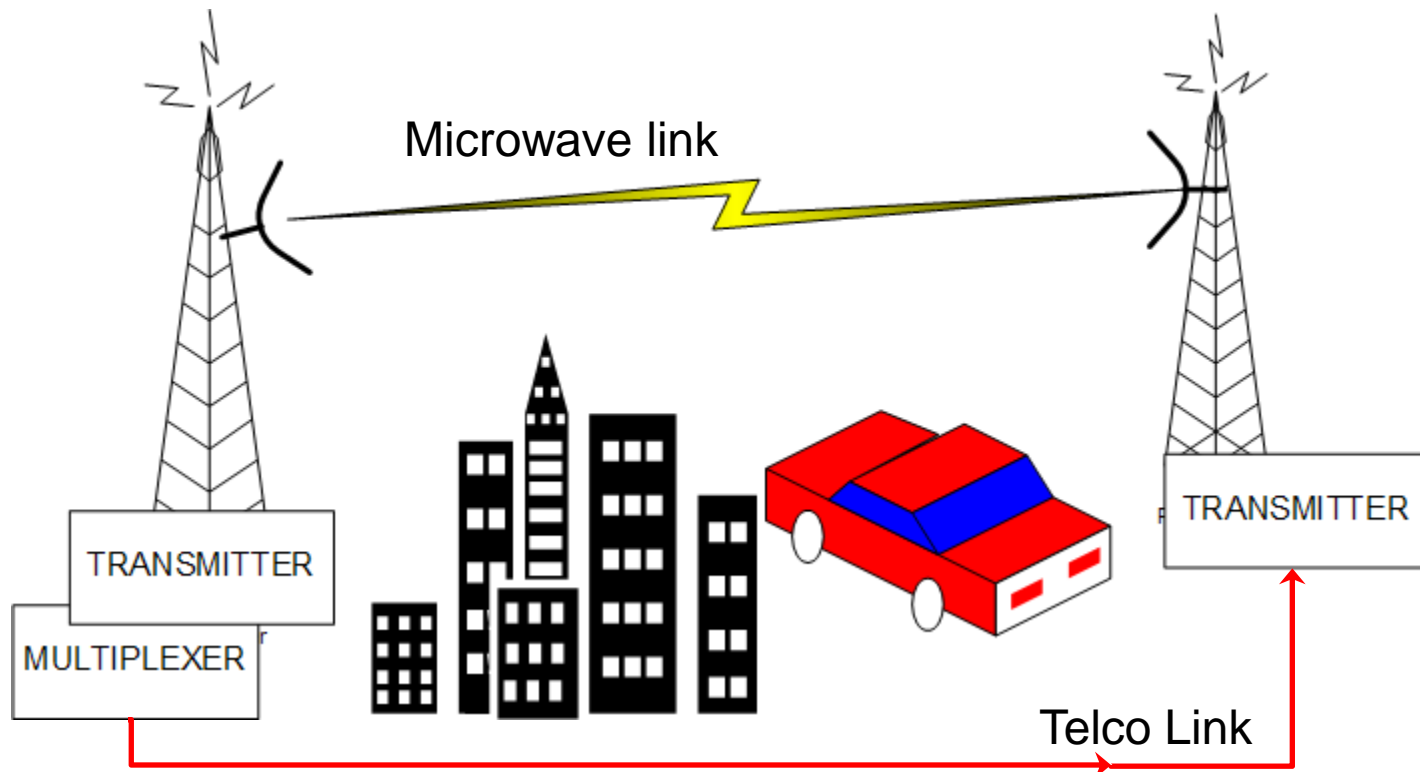

DAB+ Transmission Network Planning

SFN On Channel Repeater

Echo cancelling techniques allow repeaters to be built which can re-transmit on the same frequency

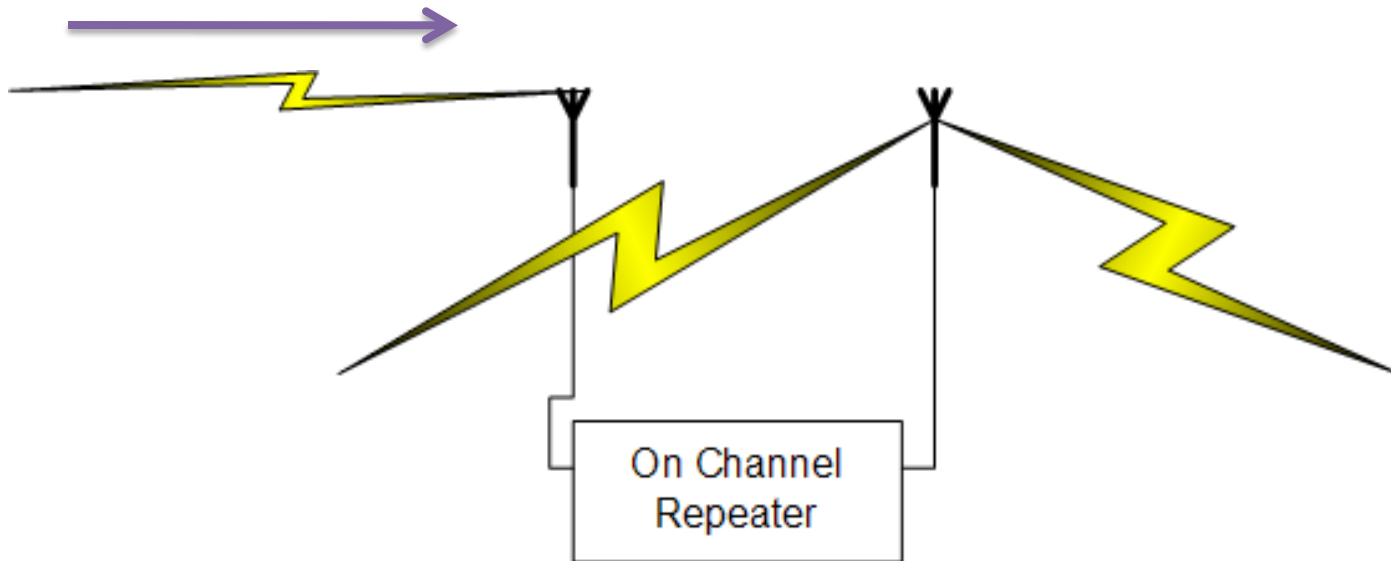

DAB+ Transmission Network Planning

Terrain, Licence Area and Interference

DAB+ Transmission Network Planning

Terrain, Licence Area and Interference Considerations

- Terrain
 - Main transmitter site efficiency, black spots and SFN
 - Australian examples
 - Adelaide easy – 1 black spot Repeater
 - Sydney much harder due to lack of high main site and undulating terrain in the far west of the LAP – multiple Repeaters
- Licence areas
 - Brisbane example
- Interference
 - Brisbane example

DAB+ Transmission Network Planning

Adelaide Licence Area



DAB+ Transmission Network Planning

Adelaide terrain viewed from the south

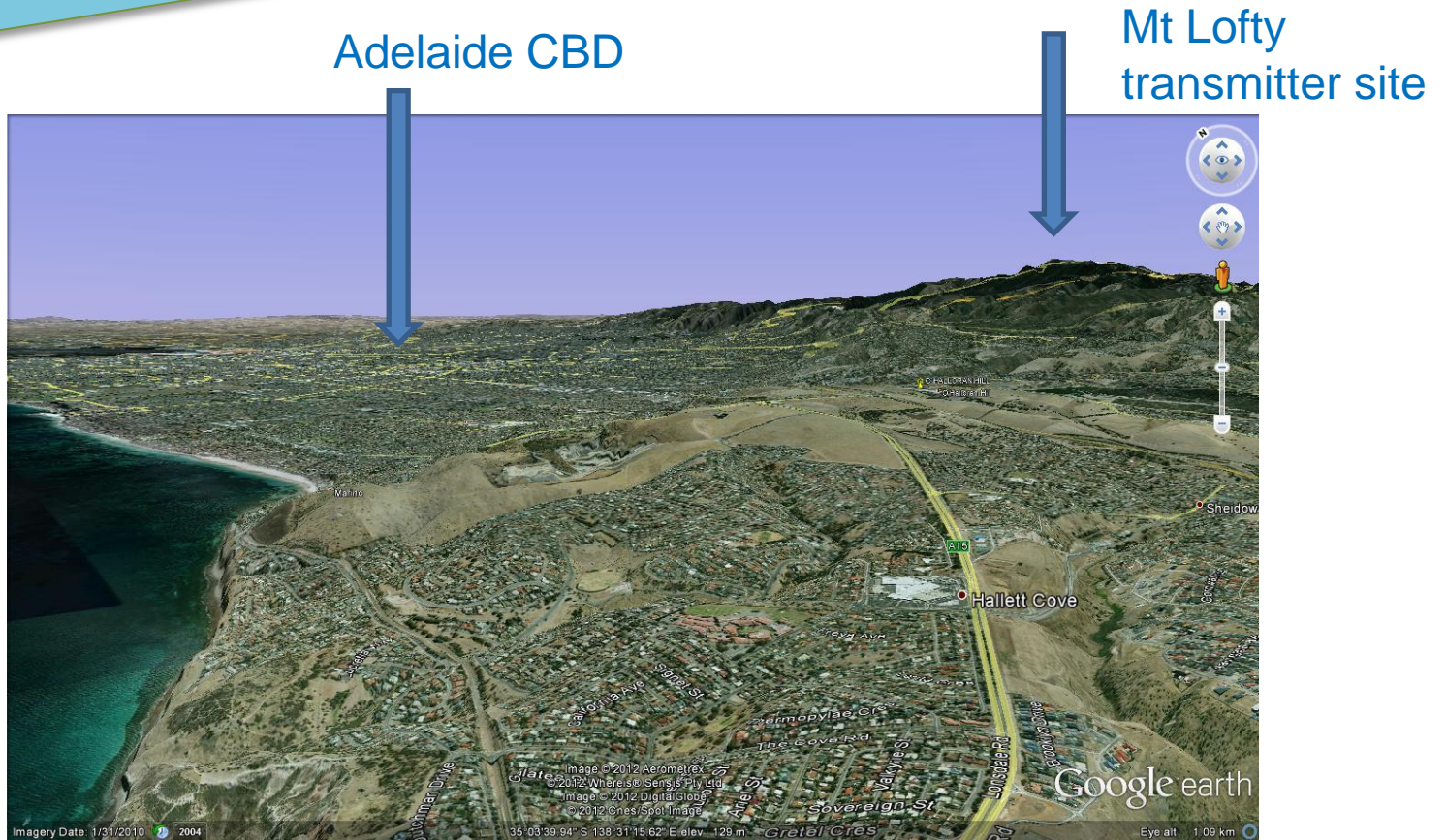

DAB+ Transmission Network Planning

Adelaide TV Towers at Mt Lofty



DAB+ Transmission Network Planning

Sydney Terrain viewed from the East

Artarmon transmitter site

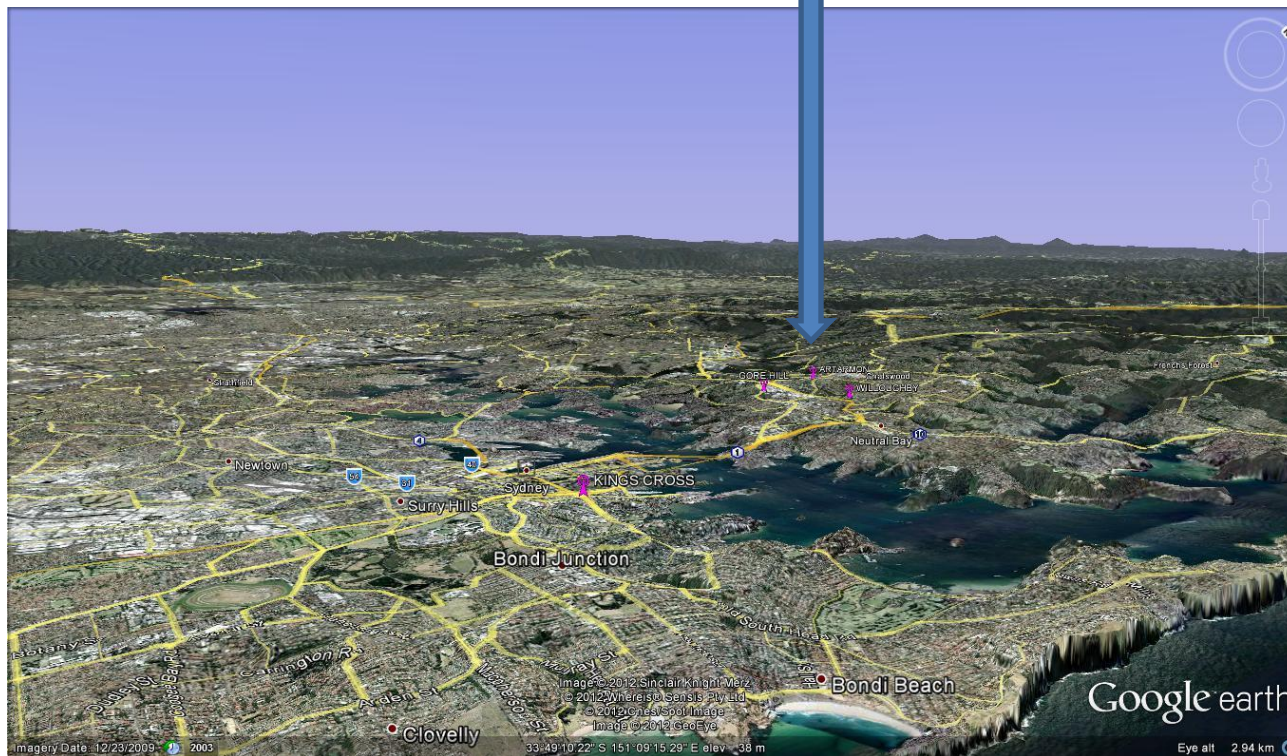

DAB+ Transmission Network Planning

Sydney Terrain – looking north over Camden valley

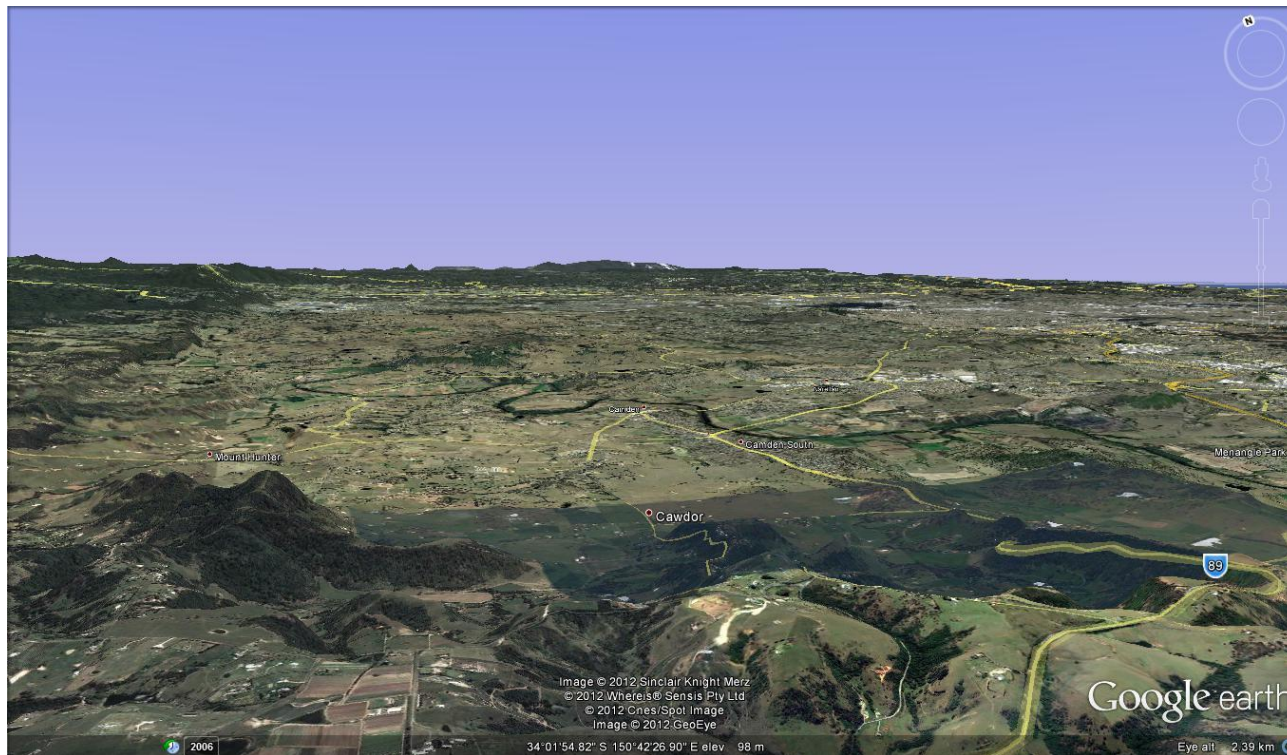

DAB+ Transmission Network Planning

Brisbane Licence Area

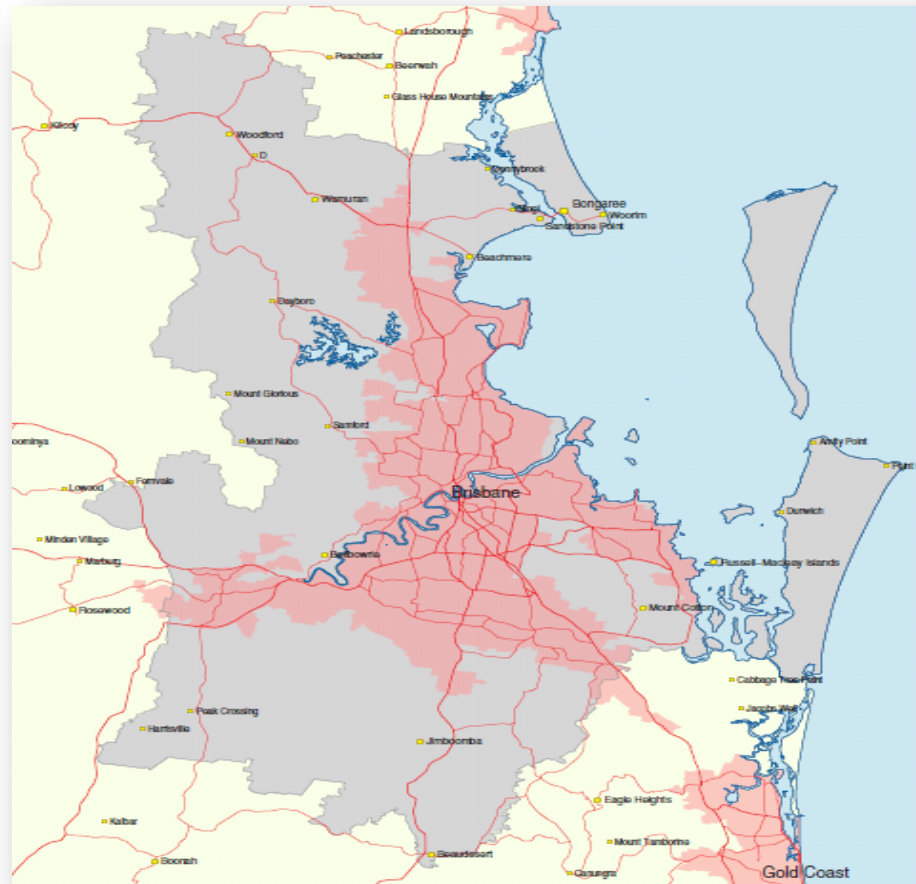

DAB+ Transmission Network Planning

Brisbane EMAX vs. ERP

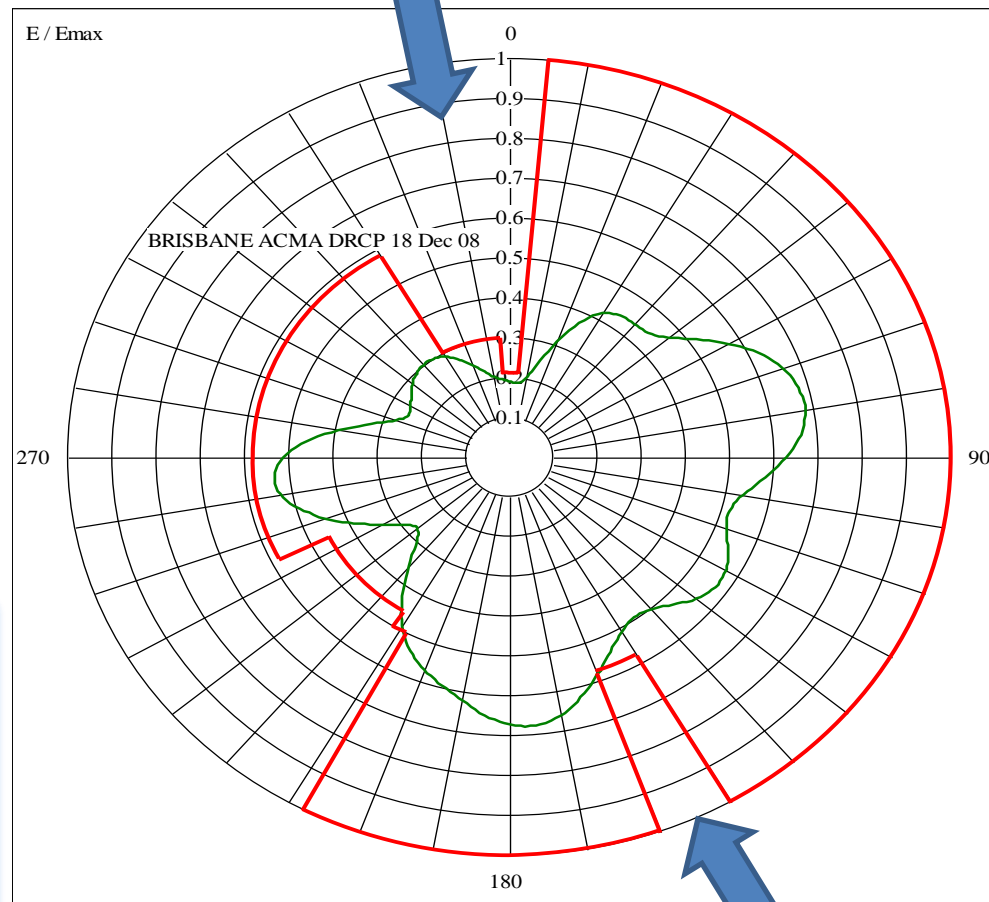

RF network design must consider interference and well as coverage

DAB+ Transmission Network Planning

Equipment and Construction

DAB+ Transmission Network Planning

Transmission Equipment Considerations

- Specification and Tendering
 - water cooling – soot issues – electrostatic dust collection
 - Dipoles vs panels
 - Notches due to tower shielding
 - Delivery of services to site
 - Microwave vs Telco options
 - Uninterruptable Power Suppliers important to minimise transmission breaks
 - Comprehensive monitoring valuable but beware cascaded alarms
- System Integration
 - Process
 - Build – site sharing and access issues
 - Factory Acceptance Test and Site Acceptance Test
- Maintenance and operations
- Repeater design and build timing

DAB+ Transmission Network Planning

Antennas



- DAB+ Signals are vertically polarised
- TV Signals are horizontally polarised (Metropolitan Markets)
- Beam Tilt techniques employed in Vertical Radiation Pattern (Allows higher ERP and more efficient Co-Channel reuse)
- Photo of combined BAND III TV & DAB+ antenna at Mount Lofty in Adelaide

DAB+ Transmission Network Planning

Performance Verification

DAB+ Transmission Network Planning

Performance Verification

- Test and verification
 - Drive testing
 - Helicopter testing – especially for complex Tx antennas
 - Tune the first and apply (where possible) to the other sites to double check expectations and assess how well design goals are met
- Example of Adelaide Helicopter Testing
- Example of Collins Street OCR

DAB+ Transmission Network Planning

Adelaide TV Towers



DAB+ Transmission Network Planning

Helicopter test antenna

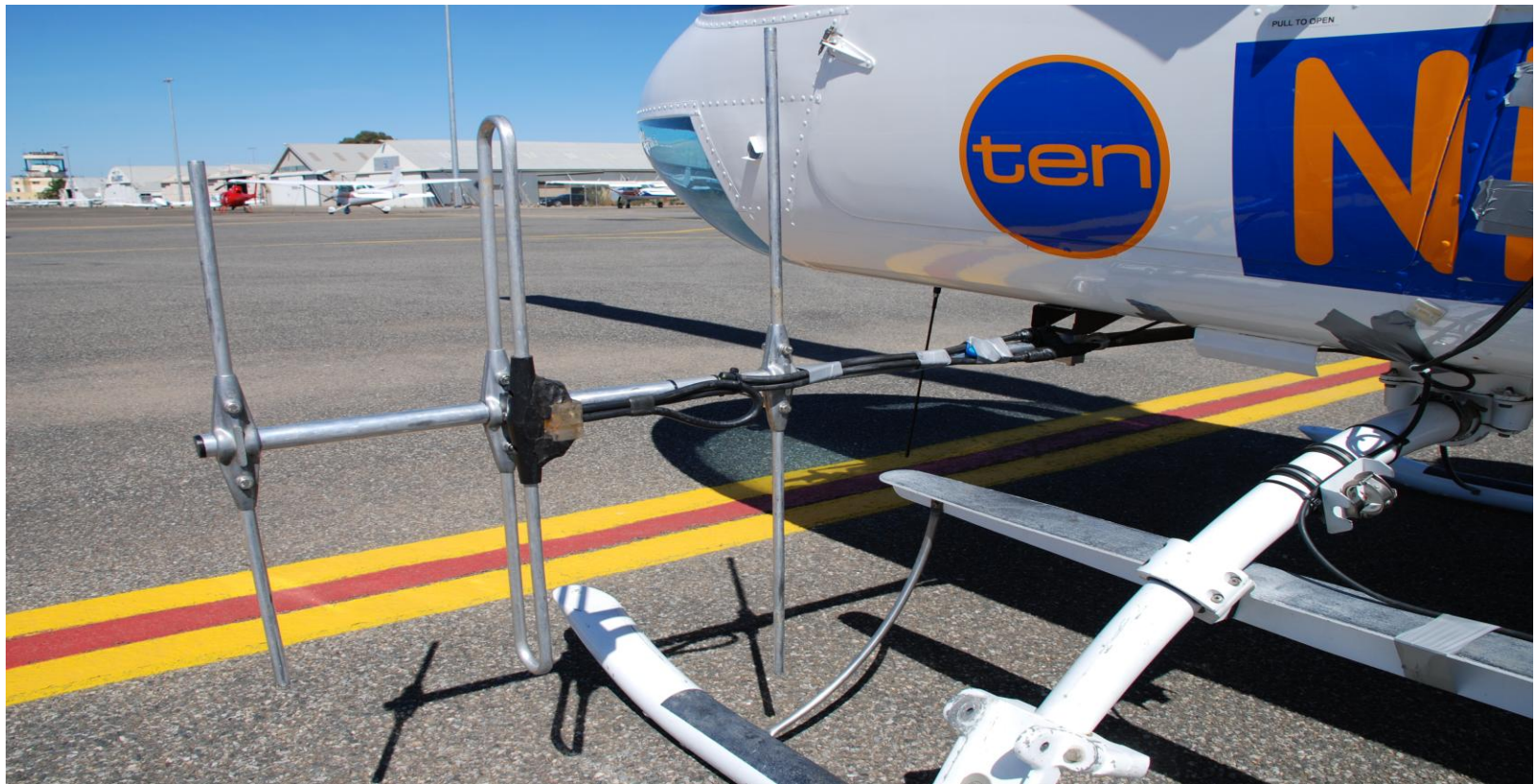

DAB+ Transmission Network Planning

Helicopter GPS antenna



DAB+ Transmission Network Planning

Measure Adelaide HRP

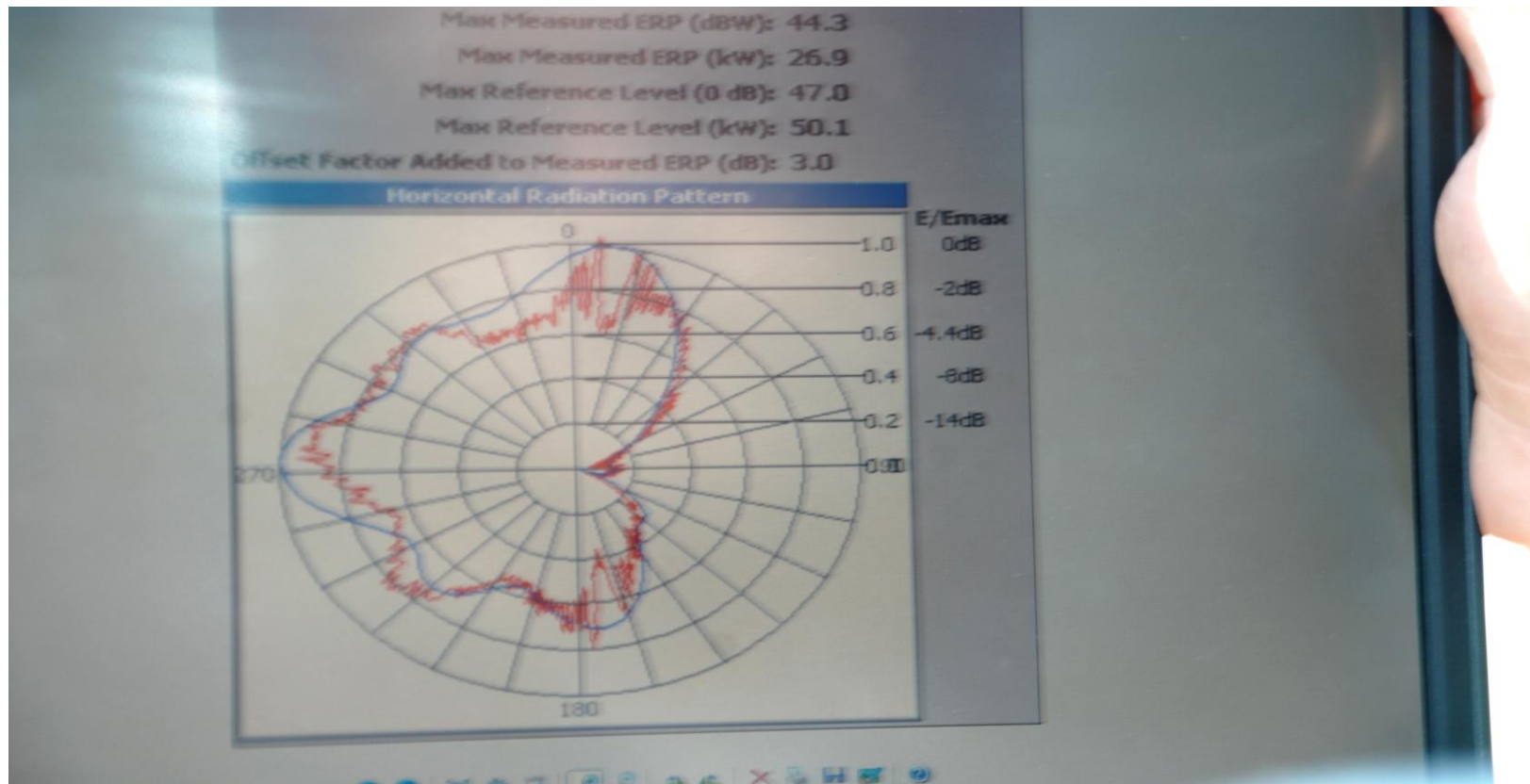

DAB+ Transmission Network Planning

Measured VRP Adelaide

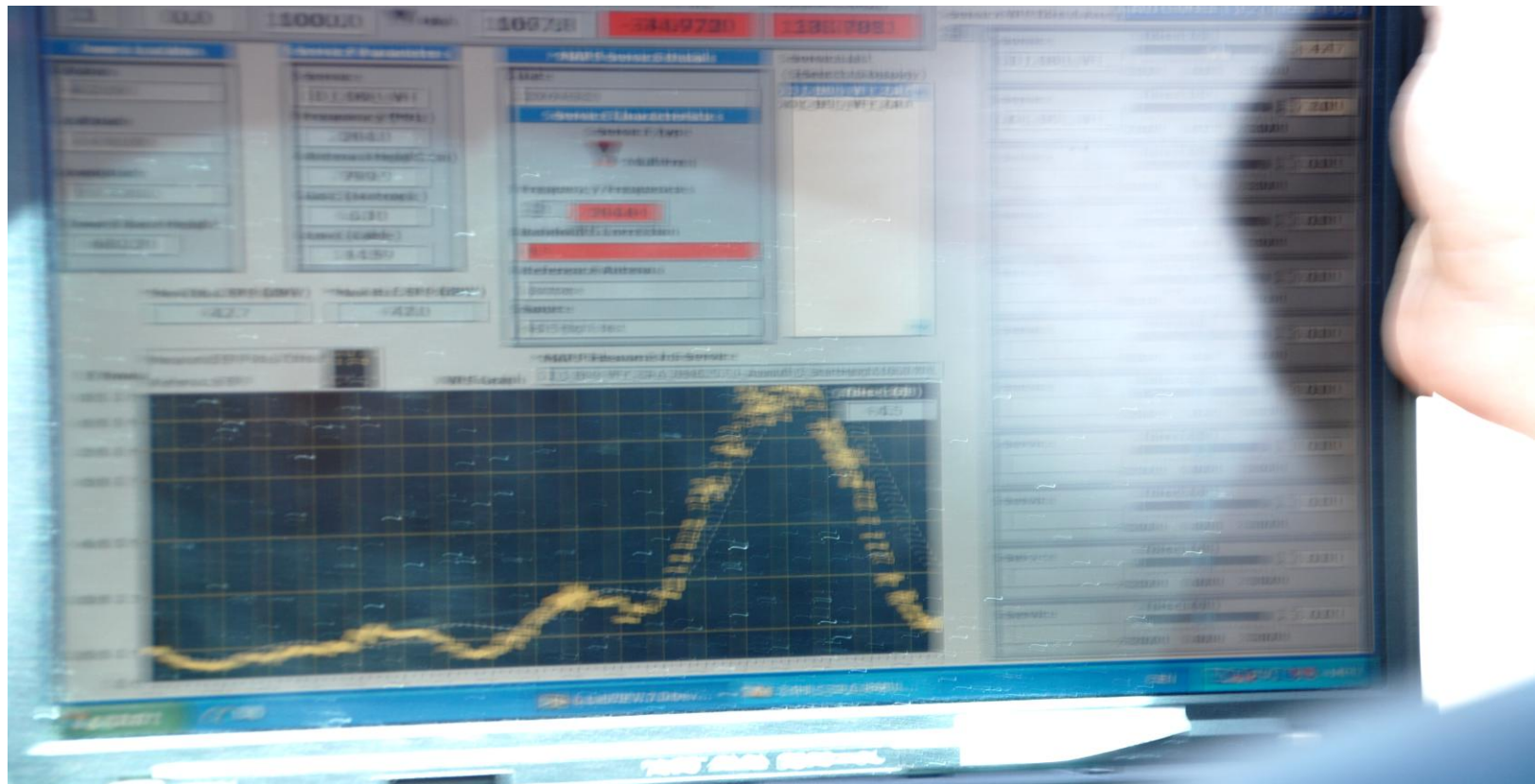

DAB+ Transmission Network Planning

Collins St. OCR Summary

- Initial trial was at 40 Watts ERP (per ensemble)
- Power was limited to prevent interference in adjacent analogue television signals.
- Trial results showed significant improvement in DAB+ reception throughout the City centre.
- No TV interference experienced (except within same building)
- Final System = 300 Watts ERP / Ensemble

DAB+ Transmission Network Planning

Block Diagram of the Melbourne OCR

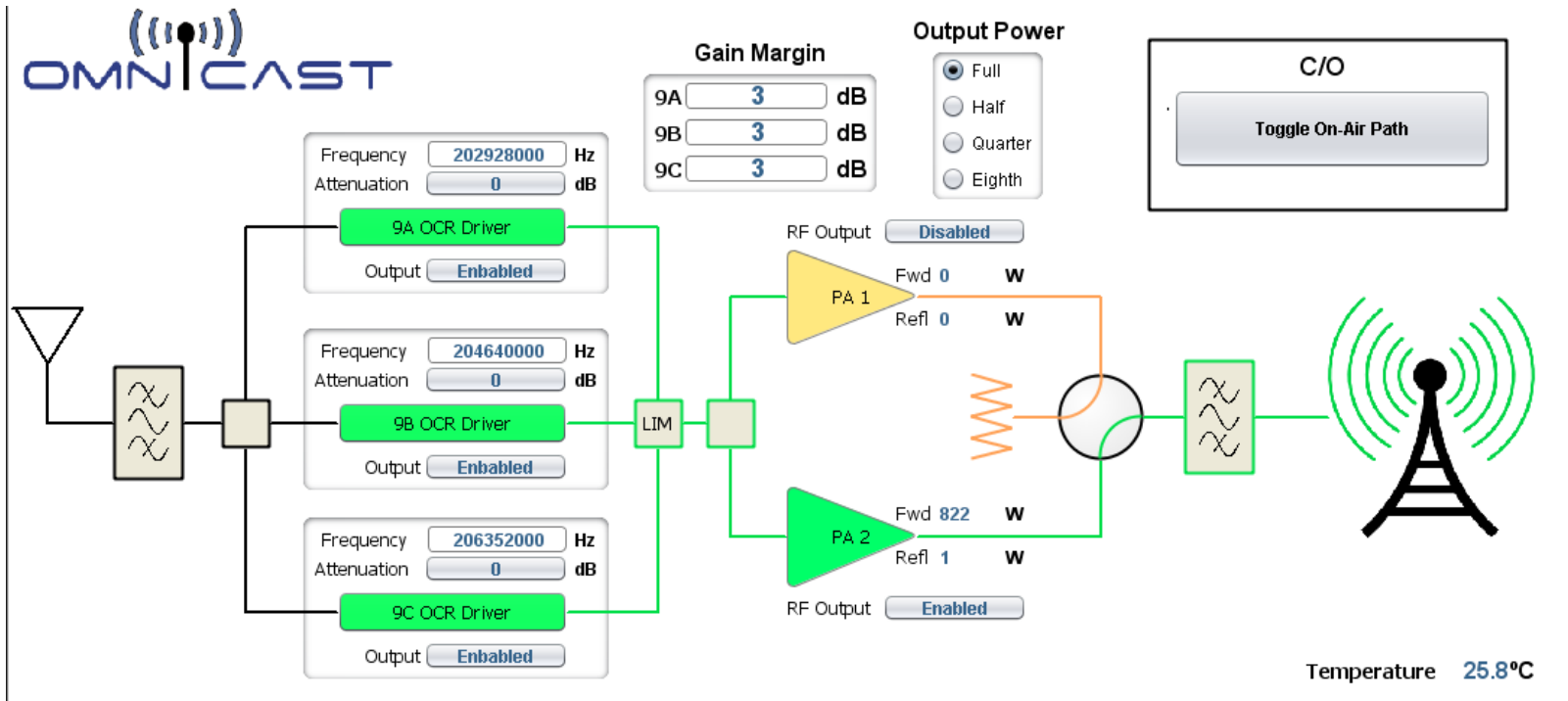

DAB+ Transmission Network Planning

DAB+ OCR Location



DAB+ Transmission Network Planning

Transmit Antenna Placement



DAB+ Transmission Network Planning

Tx & Rx Antennae

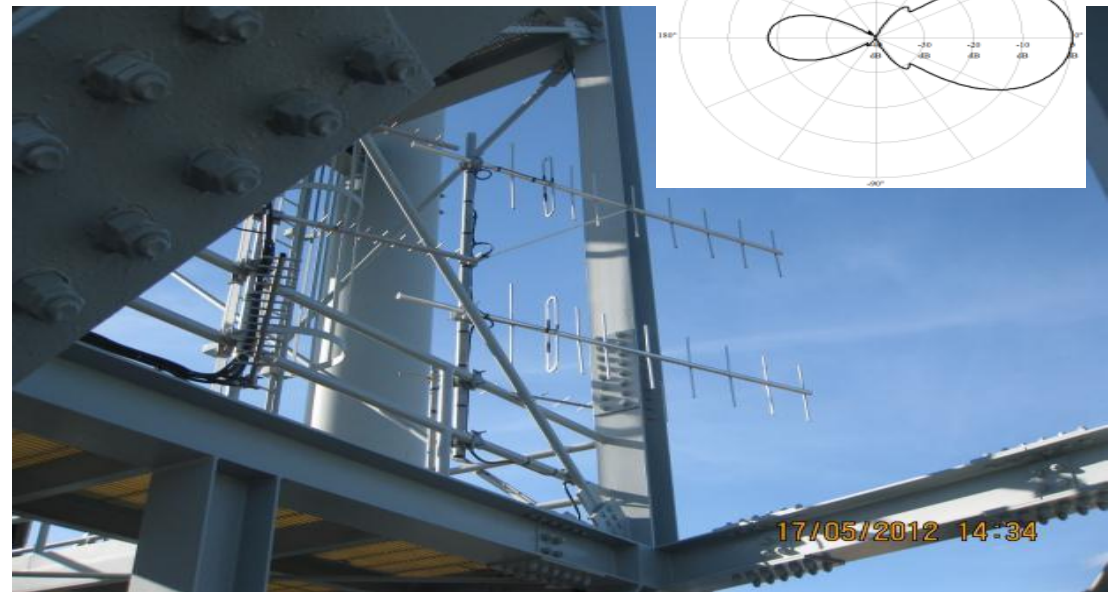
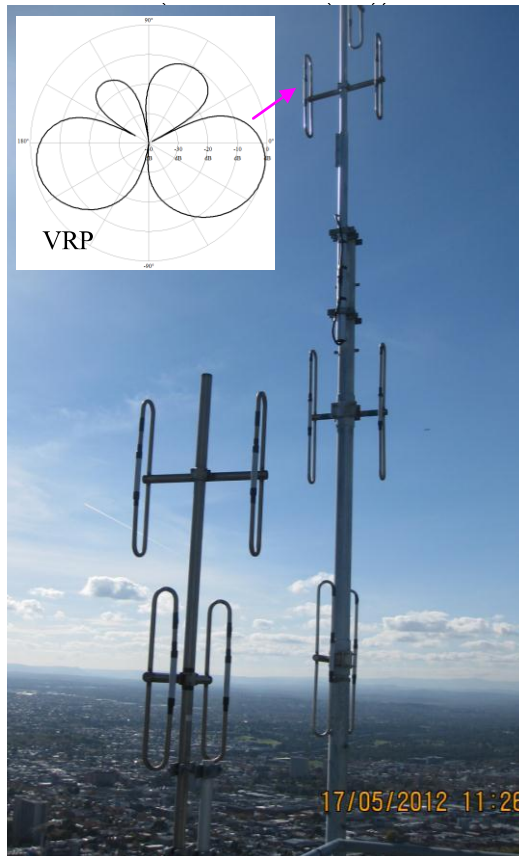

DAB+ Transmission Network Planning

DAB+ On Channel Repeater

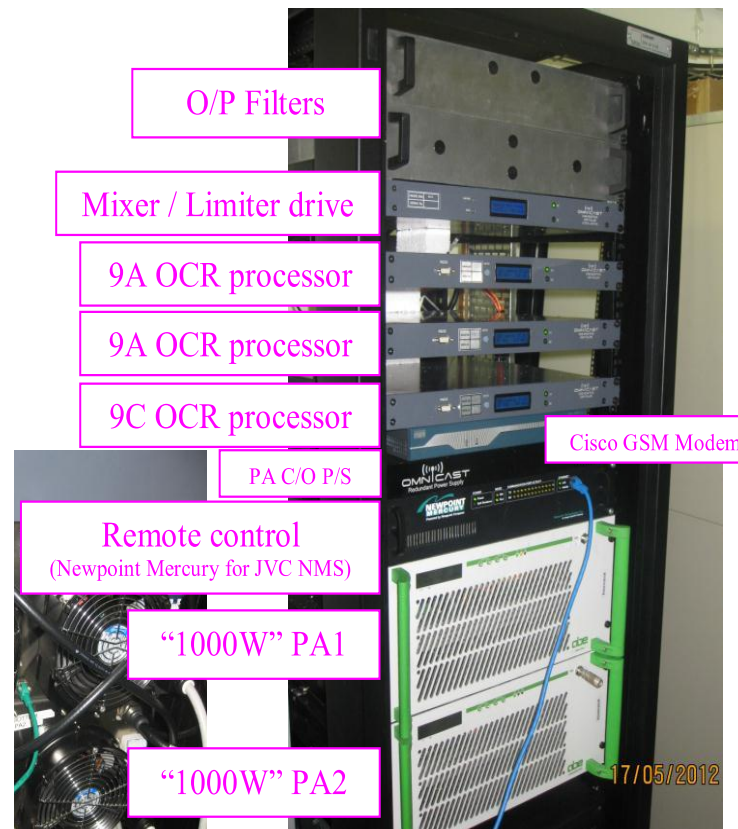

DAB+ Transmission Network Planning

Spectrum Analysis

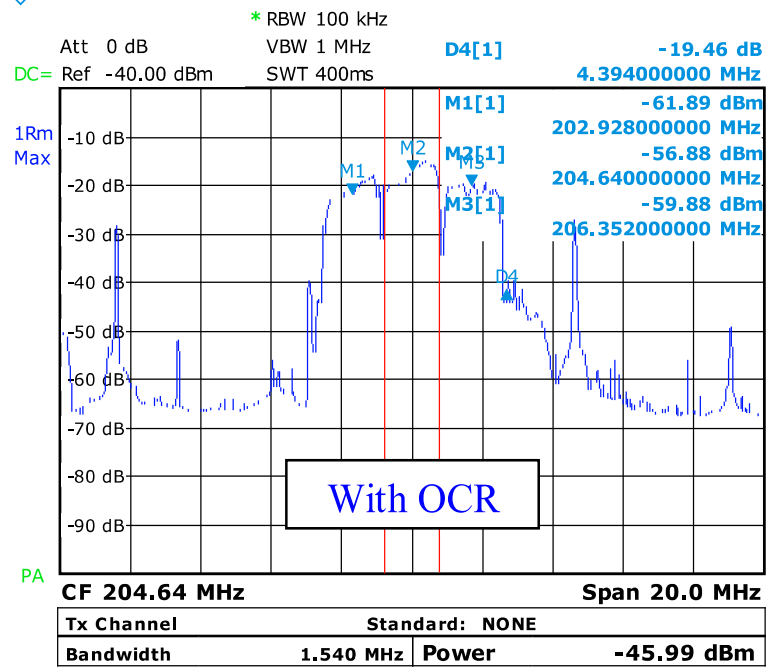
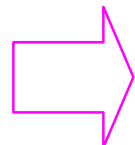
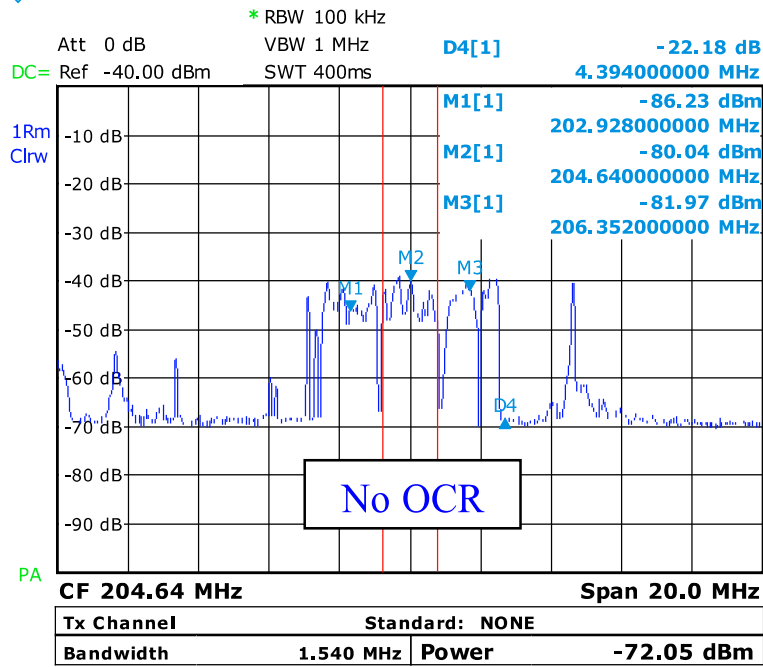

DAB+ Transmission Network Planning

Measurement Locations – OCR Off

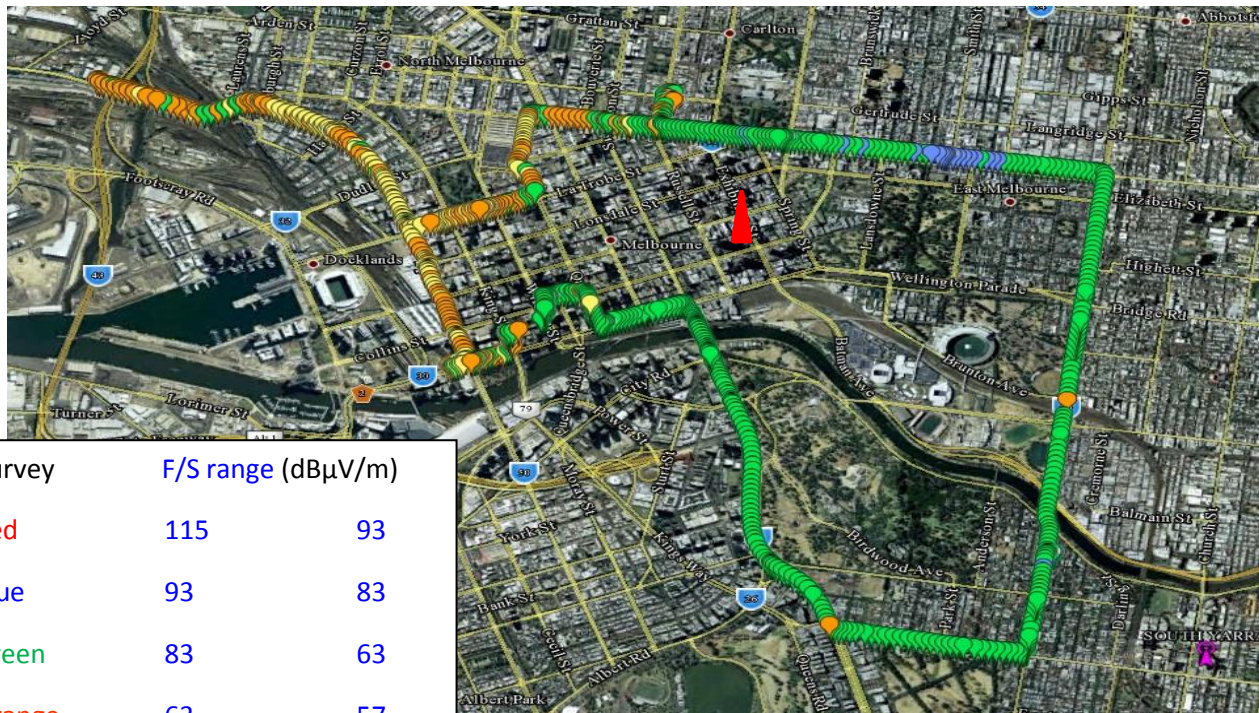

| Prediction | Survey | F/S range (dB μ V/m) | |
|------------|------------|--------------------------|----|
| Blue | Red | 115 | 93 |
| | Blue | 93 | 83 |
| Green | Green | 83 | 63 |
| Brown | Orange | 63 | 57 |
| Yellow | Yellow | 57 | 50 |
| White | Yellow-dot | 50 | 35 |
| | Light blue | 35 | 25 |

DAB+ Transmission Network Planning

Measurement Locations – OCR On

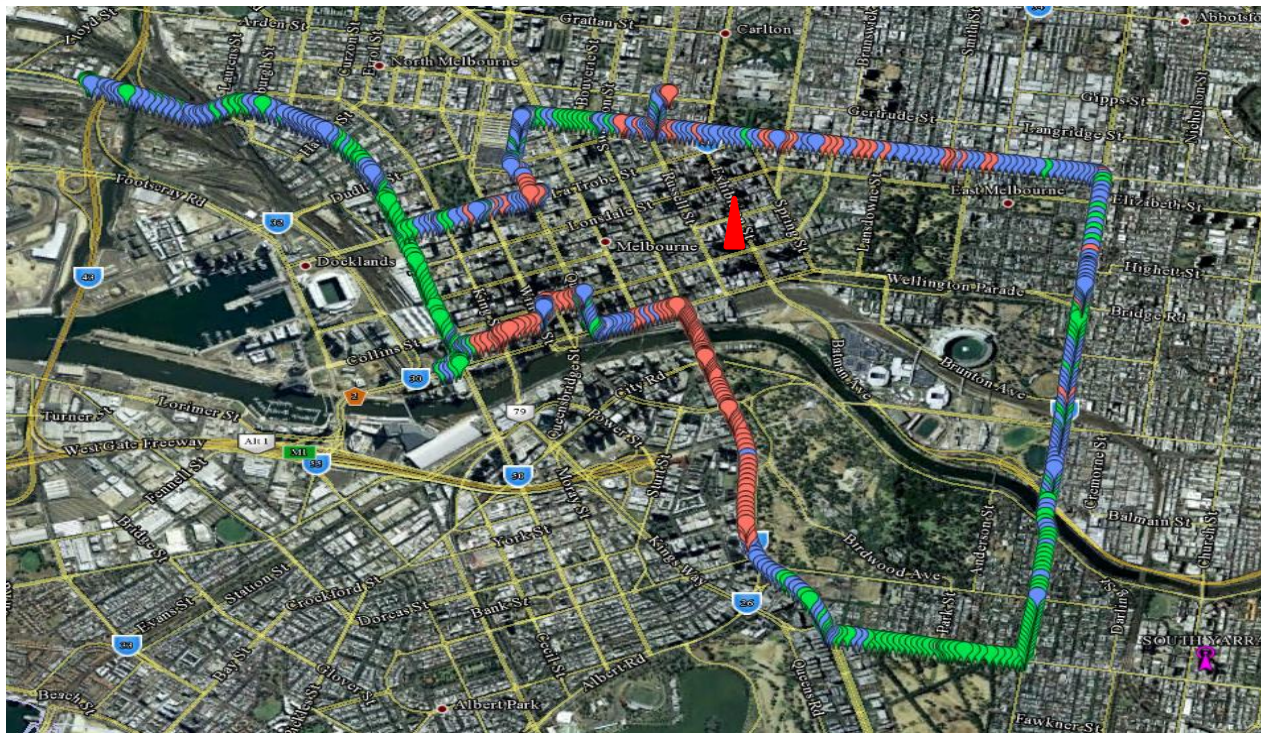

DAB+ Transmission Network Planning

The Journey Continues

DAB+ Transmission Network Planning

Planning DAB+ for Regional Australia

- Initial design focused on the area around Greater Sydney area
 - A wide range of terrains
 - Wide range of population densities
 - Is the most closely packed in Australia
 - the most difficult to plan CCI and ACI
- All Regional Commercial Broadcasters have estimated how many Main, SFN & OCR sites will be required to service their individual LAP's
- CRA have developed Capital Expenditure and Operational Expenditure models and are now in discussion with Government for the rollout of DAB+ Radio to Regional Australia

DAB+ Transmission Network Planning

System Design

The Next Steps:

- Agreement on overall objectives between
 - Commercial Broadcasters – number of services and coverage
 - National Broadcasters – number of services and coverage
 - The Regulator – fair play, no interference
 - The Government - funding
- Proposal to Government and Funding Agreement
- Detailed Planning and Modeling of all LAPs
- Equipment Design and Tendering
- Build and Verify

There is always
some iteration in this
process

DAB+ Transmission Network Planning

Summary – Top 10 Tips

1. Know what you want to achieve – the BIG PICTURE
2. Be **Collaborative in Engineering** the system – **Competitive on Content**
3. Work with your Regulator to ensure that all parties are considered
4. A successful rollout will require consultation with retailers, automotive etc
5. Use the design cycle to your advantage – process is important
6. RF Coverage modelling is essential
7. Beware of Co-Channel Interference and Adjacent Channel Interference
8. Bulk purchase and equipment standardisation provides big savings
9. Systems Integration requires detailed planning
10. Always verify your design – tuning will probably be required!

DAB+ Transmission Network Planning

Thank You

les.sabel@commercialradio.com.au